

Plan View

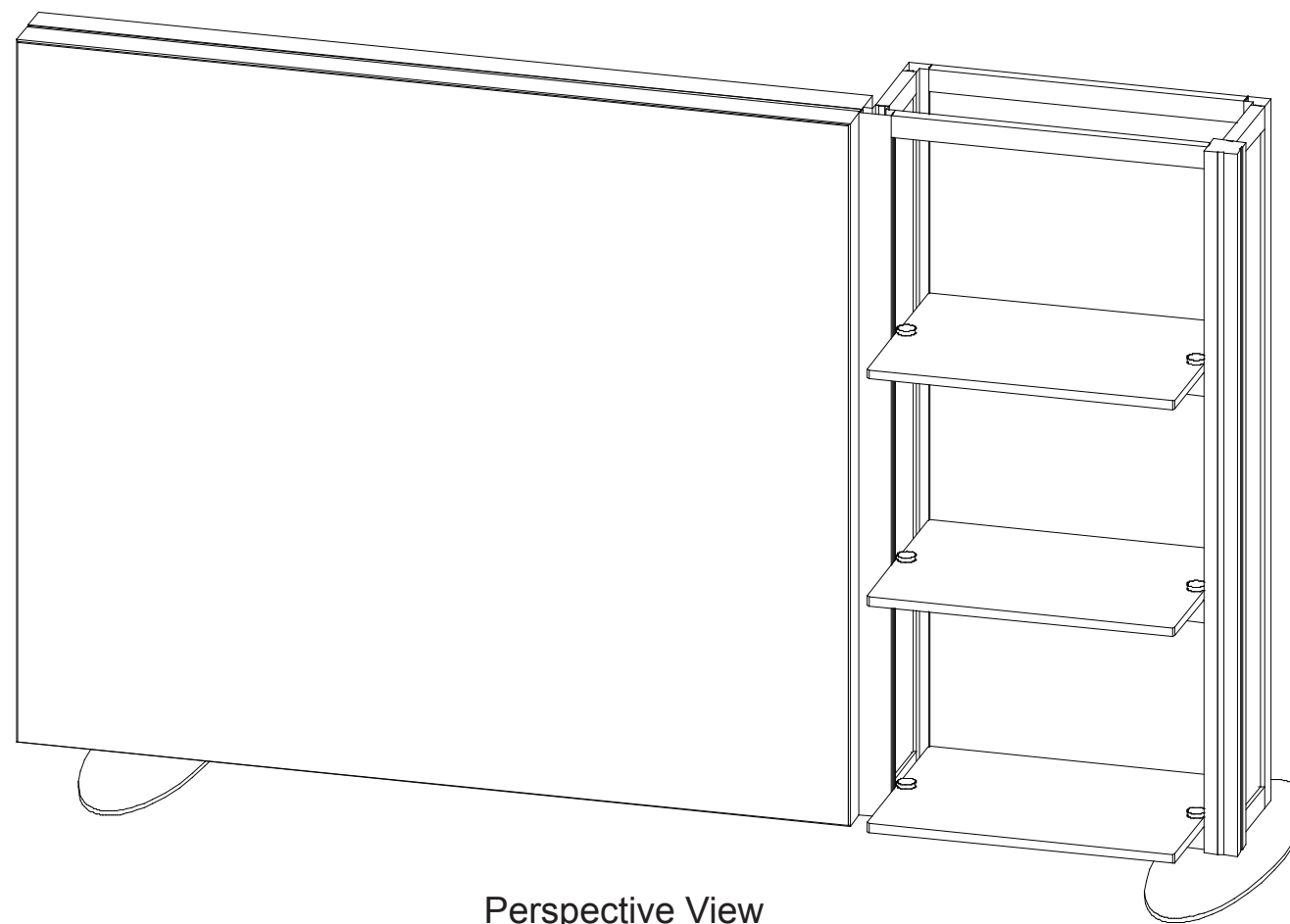

Perspective View

General Setup Instructions

- Read entire setup instruction manual prior to unpacking parts and pieces.
- The setup instructions are created specifically for this configuration.
- Setup instructions are laid out sequentially in steps, including exploded views with detailed explanation for assembly.

Cleaning & Packing

- For Cleaning Metal, Plex, & Laminate Parts: Use a **MILD NON-ABRASIVE** cleanser and soft cloth/paper towel to clean all surfaces.
- Keep exhibit components away from heat and prolonged sun exposure.
Heat and UV exposure will warp and fade components.
- Retain all provided Packing Materials. All provided packing materials are for ease of repacking & component protection.

Disassembly

- For loss prevention, tighten all setscrews and locks during disassembly

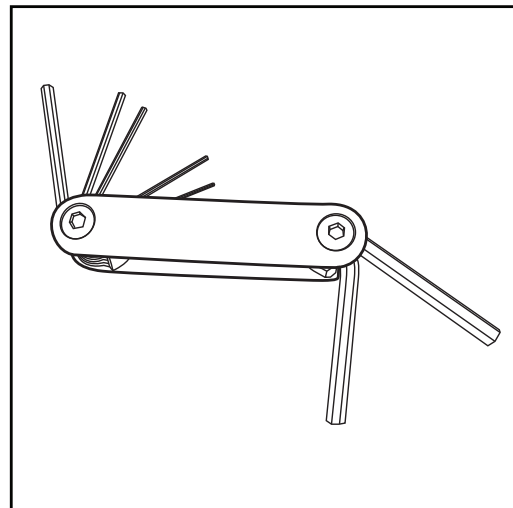

Hex Tool - Essential for Assembly

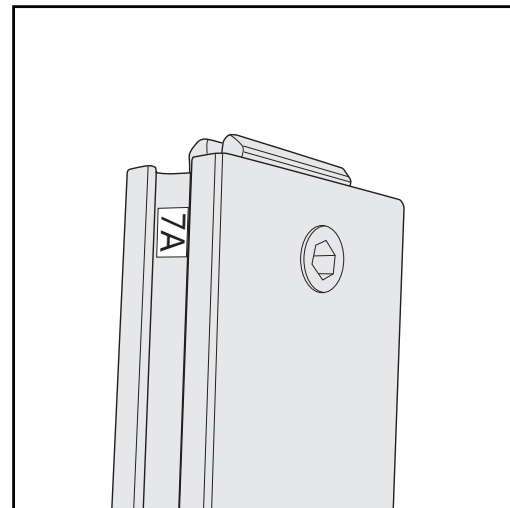

Part Identification - Numbering

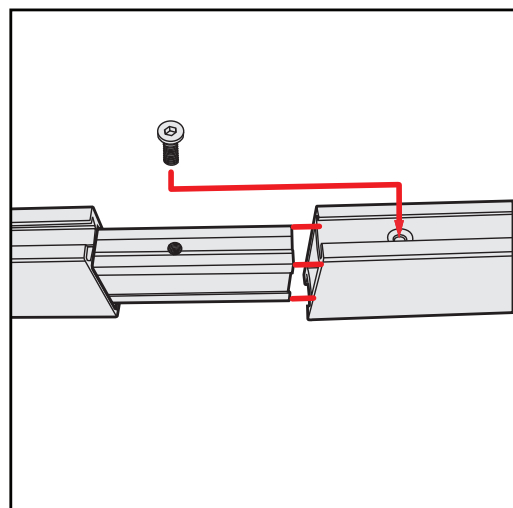

Spline Connection

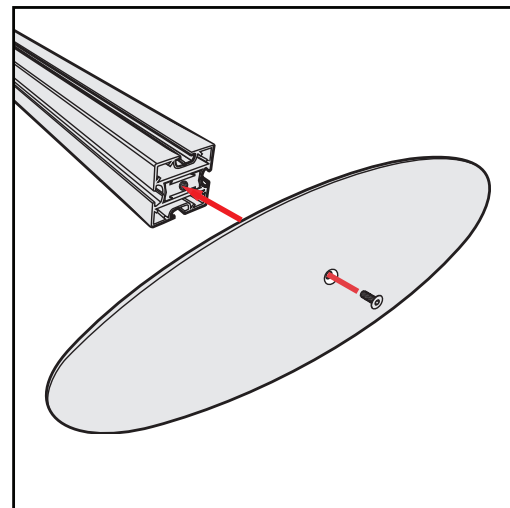

Base Plate & Extrusion Connection

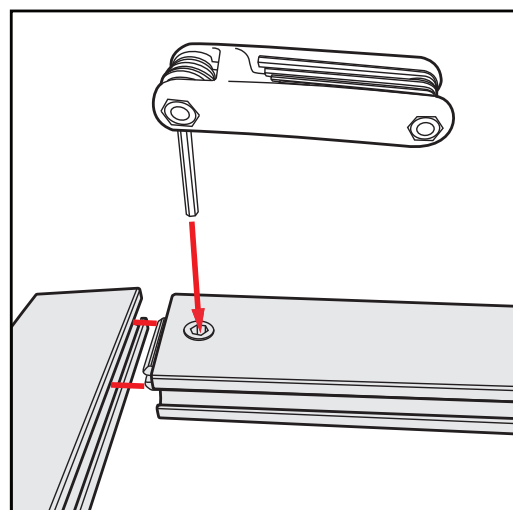

Extrusion & Lock Connection

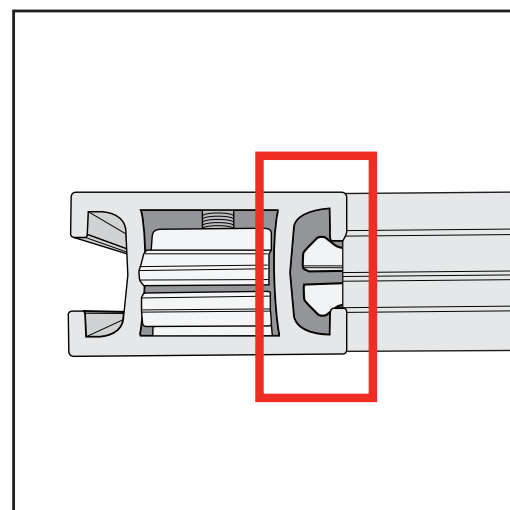

Engaged Lock



WARNING

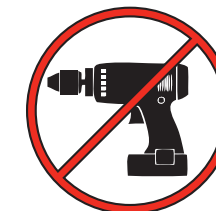

DO NOT USE POWER TOOLS



LADDERS OR LIFTS
MAY BE REQUIRED



ALL CONNECTIONS MUST
BE TIGHTLY SECURED

SEG Graphic Installation

- 1) Locate channels along the edges of extrusions
- 2) Insert graphic corners first into channels then center point of graphic into channels. Allows for proportional fit around the perimeter of the extrusion.
- 3) Working from center to corner, slide silicon edge on graphic into channel.
- 4) After all edges of graphic have been inserted into channels, step back and assess graphic fit, make adjustments where needed.

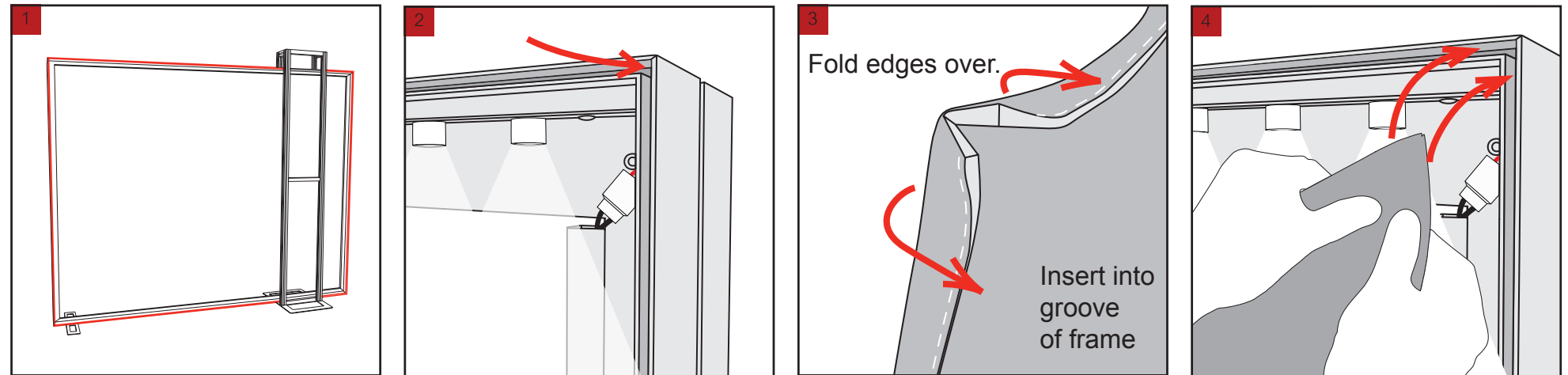

Corner Bracket Installation

- 1) Slide TWO-PIECE **TS RV 2** L-bracket into Interior Center Slot of extrusion so that two set screws are inside groove. Tighten two set screws to secure.
- 2) Slide two **A1** L-Brackets into outer interior grooves of upper and lower horizontals. Tighten set screws to secure.
- 3) Slide vertical extrusion over exposed ends of brackets in lower horizontal. Tighten set screws to secure.
- 4) Slide exposed ends of installed brackets of upper horizontal into open ends of verticals. Tighten set screws to secure.

Disassembly

- 1) Loosen set screws on brackets and slide extrusions off of brackets.

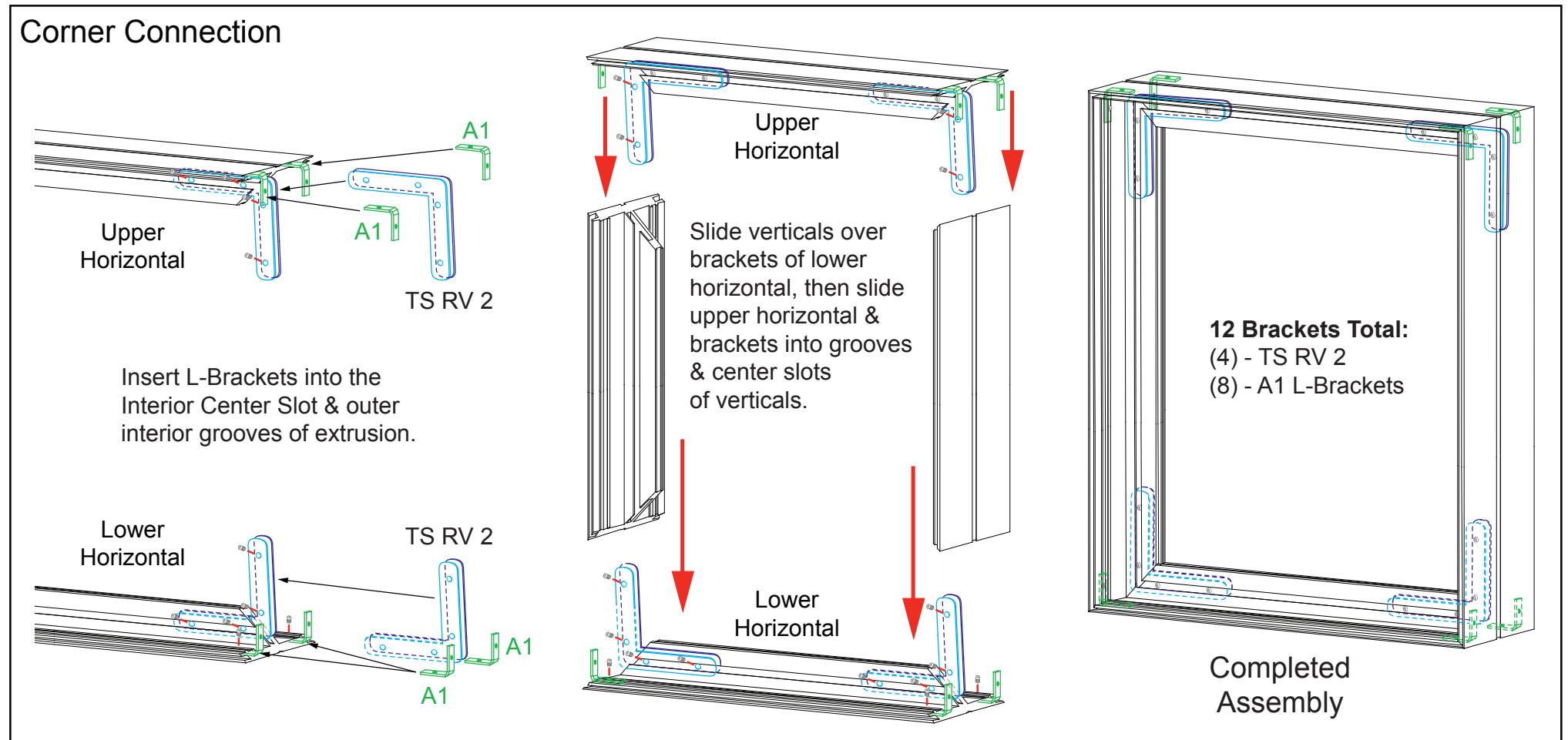

Top View of Each Level

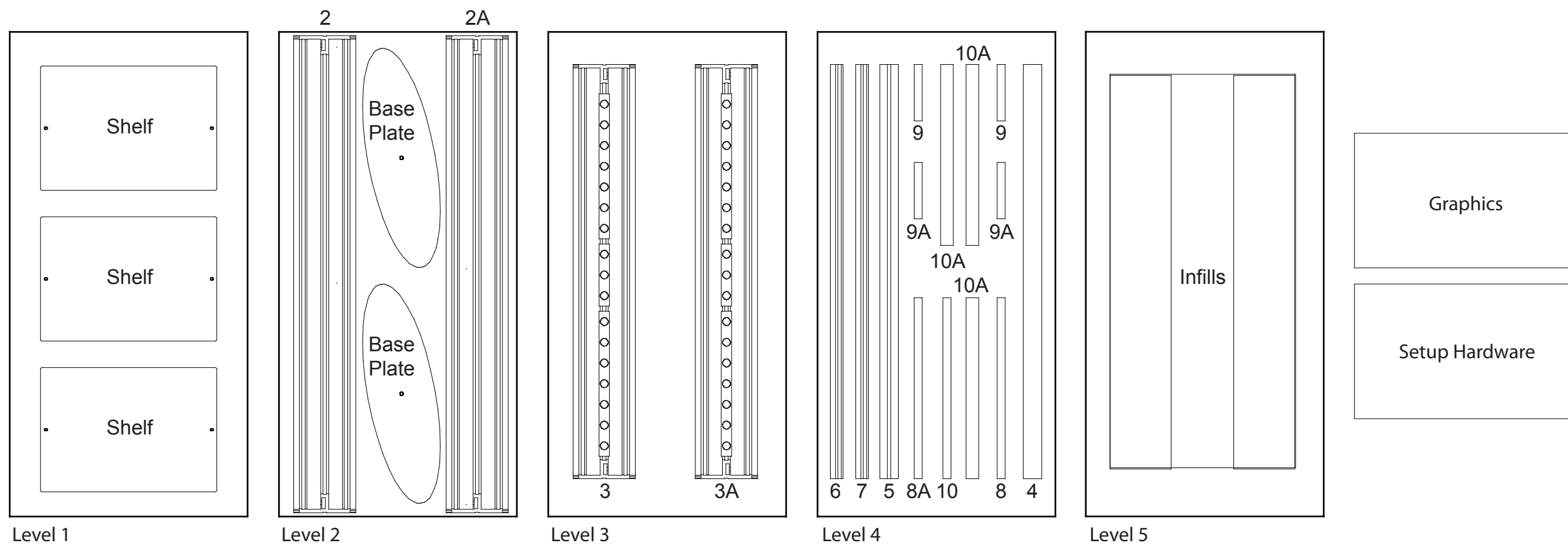

Item	Qty.	Description
1/1A	1/1	Base Plate
2/2A	1/1	46" CEI152 Horizontal Extrusion
3/3A	1/1	40" CEI152 Vertical Extrusion
4	1	40" GS220 Vertical Extrusion
5	1	40" S44 Vertical Extrusion
6	1	40" GS220 Vertical Extrusion
7	1	40" GS220 Vertical Extrusion
8/8A	1/1	17.4075" Z45 Horizontal Extrusion
9/9A	2/2	5.4022" Z45 Horizontal Extrusion
10/10A	1/3	17.3976" Z45 Horizontal Extrusion

- Steps:**
- 1) Attach Base Plate [1] to Horizontal [2], using Bolt, Washer, and Wing Nut.
 - 2) Attach Base Plate [1A] to Vertical [5], using Bolt.
 - 3) Assemble lightbox frame [2,2A,3,3A] together. See General Information page for Corner Bracket Installation details.
 - 4) Assemble Verticals [4,5,6,7], using Horizontals [8,9].
 - 5) Slide Infills between and secure with Horizontals [8A,9A] on top.
 - 6) Connect Vertical [4] to Vertical [3A]. See **GS300 to CEI152 Connection** detail.
 - 6) Attach Horizontals [10,10A] between Verticals [4,5].
 - 7) Connect Shelves to Horizontals [10A], using Connectors and Caps. See **Shelf Connection** detail.

